



DESIGO RX

Room unit with PPS2 interface

QAX34.3

For use with:

- Equipment from the RXC, RXB, RXL and RXA (PPS2) ranges
- DESIGO PX automation stations¹⁾
- Devices with a PPS2 interface

- **Measurement of the room temperature**
- **Bias switch for adjustment of the room temperature setpoint**
- **Bias switch for selection of the operating mode (⏻/Auto) and for manual control of the fan in fan-coil systems (up to 3 speeds)**
- **LCD for display of room temperature and operating mode**
- **PPS2 interface to the controller**
- **Tool function for parameter setting and testing²⁾ of RXB/RXL controllers**

Application

As a room unit:

The room unit is used in rooms controlled by an individual room control system, to measure the room temperature and for operation of a room controller. The functions of the LCD display are determined by the controller. If manual fan-speed control is enabled, the room unit can be used to operate a fan-coil system.

It is also suitable for use in conjunction with a DESIGO PX automation station¹⁾.

As a tool:

In conjunction with the RXB / RXL controllers (FC-10 and later, CC-02) the QAX34.3 room unit can also be used for parameter-setting and for the wiring test²⁾.

For details refer to the technical manual, CM110389 (RXB), CM110789 (RXL).

- 1) In the QAX34.3 room unit the address (fixed to 1) cannot be changed.
If it is used with a PXC... automation station, the display shows the state requested by the user (see page 3), rather than the actual state.
- 2) Wiring test only available with devices from index D (inside the housing, see page 2).

Ordering

When ordering, please specify the quantity, product name and type code.

Example:

30 Room units QAX34.3

Compatibility

The room unit can be used with all controllers incorporating a PPS2 room unit interface (e.g. DESIGO RX and DESIGO PX ¹⁾).

- 1) The QAX34.3 room unit only works with Address 1. If it is used with a PXC... automation station, the display shows the state requested by the user, rather than the actual state.

Mechanical design

The room unit is suitable for mounting on a recessed conduit box. The cable entry is through the rear.

For surface mounting, with the cable entry at the top or bottom, accessory ARG70.2 is required.

Basically the unit comprises the housing and the mounting plate. These can be locked together and released by a snap-mechanism.

The mounting plate incorporates the screw terminals.

The housing accommodates a printed circuit board, room temperature sensor element, bias switches for setpoint adjustment and selection of the operating mode and fan speed, and the LCD panel.

The housing and mounting plate are plastic.

Opening the housing

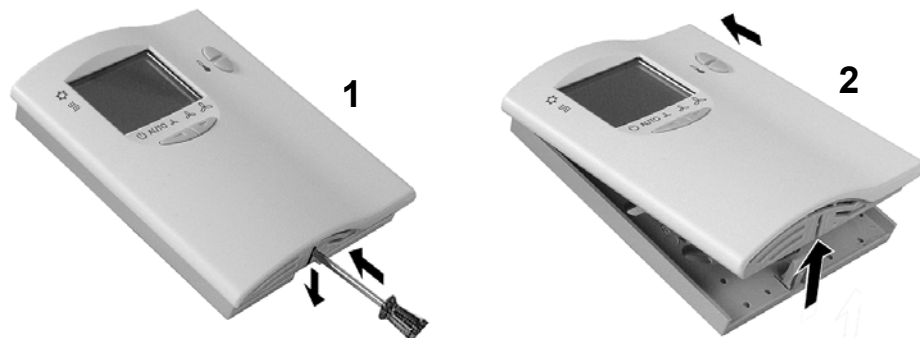

Index and manufacturing date



Operator controls and display panel

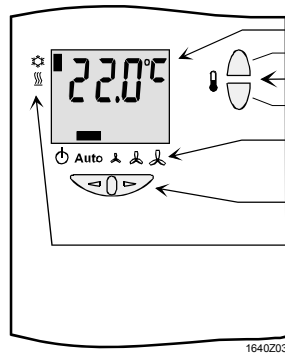

- 1 Display of actual room temperature or adjustment value, and bar indicating sequence (heating/cooling), operating mode and fan speed.
- 2 Buttons for room temperature and setpoint adjustment
- 3 Symbols for operating mode and fan speed
- 4 Buttons for operating mode and fan speed
- 5 Symbols for the sequence (heating/cooling)

Note The controller determines the actual functions of the buttons and display (based on the selected application and the associated parameters). The following describes all the functions of the elements illustrated.

Button for selecting the operating mode and fan speed

This button can be used like an occupancy button to determine the operating mode. Three manual fan speeds can also be defined. Pressing the left arrow once selects the option one step to the left, and pressing the right arrow once selects the option one step to the right. The currently active operating mode or the manually selected fan speed is indicated by a bar above the relevant symbol.

Button for adjusting the room temperature setpoint

When the button is pressed for the first time, the LCD display switches from room temperature to setpoint display. Each additional operation of the upper or lower button increases or reduces the setpoint by 0.5 K or 1.0 °F (the engineering unit is predetermined by the controller). The maximum possible adjustment range is also defined by the controller.

LCD panel

The following display options are possible in normal operation (actual options determined by the controller). For details refer to the application description for the controller range concerned. For information on parameter-setting refer to the technical manual, documents CM110389 (RXB) and CM110789 (RXL).

	Room temperature in °C (resolution 0.5 °C)
	Room temperature in °F (resolution 1.0 °F)
	Setpoint adjustment displayed in digits (Displayed only while adjusting the relative setpoint)
	Scale and digits (Displayed only when adjusting the absolute setpoint)
	Cooling sequence is active
	Heating sequence (If the bar is not shown against either sequence, then the controller is operating the dead band)
	Economy operating mode Automatic fan control
	Comfort operating mode Automatic fan control
	Comfort operating mode Manual fan control, fan speed 1

The room unit receives its power from the connected controller via the PPS2 interface (low voltage, SELV).

Only one room unit can be connected to an RX... room controller.

When connecting a room unit to a PXC... automation station, the room unit must be Address 1 (this address is permanently programmed in the room unit).

The room unit must be connected to the room controller with a two-core twisted pair cable. See the relevant installation guide (RXC: CA110334; RXB & RXL: CM110381; RXA: CA2Z3884). Unscreened cable may be used.

Mounting instructions

- The device is suitable both for surface mounting and for installation in a recessed conduit box
- The unit should not be mounted in recesses, shelving, behind curtains or doors or above or near direct heat sources
- Avoid direct sun and draughts
- The conduit must be sealed on the device side, as currents of air in the conduit can affect the sensor reading
- The admissible ambient conditions must be observed.
- Mounting instructions are enclosed with the device.
- A set of fixing accessories is enclosed with the device.

Installation

Local installation regulations must be observed.



Warning

The equipment is not protected against accidental connection to AC 230 V.

Commissioning

Start-up characteristics

After an interruption of the connection to the PPS2 interface, communication is only re-established when the connected room controller next polls the PPS2 addresses.

The cycle times are as follows:

RXA: 10 seconds; RXB, RXL, and RXC: 3 minutes; PX: 30 seconds

When the supply voltage is connected (via the PPS2 interface) or in the event of a reset via the room controller, the following routine is executed in the room unit:

Step	Function	Description
1	LCD test	All segments of the display module are operated for approx. 3 s
2	Identification by controller	Until the controller recognizes the room unit as a PPS2 user, the display reads:
3	Ready for operation	1 s after recognition by the controller, the room unit is ready for operation

Displaying the “Wink” function of KNX/EIB and LonWORKS devices

If the room unit is connected to a room controller in the DESIGO RXB, RXL or RXC range, the display can be used as an aid to commissioning. If the commissioning tool is used to transmit a Wink command, the room unit displays the type of room controller connected. For example:

Room controller type	Display
RXB 21.1, RXL21.1, RXC21.1,	r. 21
RXC30.1	r. 30

Operating notes

During commissioning and operation, the LCD panel displays error messages:

Display	Description	Type of error
C02	C: No communication with controller for over 64 s 02: Firmware version (e.g. Version 2.0)	D
E 1	Room temperature sensor outside range 0 ... 40 °C	S
E 15	The room controller has not yet added the room unit to its list of members (during controller start-up)	D
E 17	The room controller does not recognize room unit type	D
0.0	Initial value, after room unit is switched on and before a room controller has sent a value.	S
99.5	Room controller has not transmitted a valid temperature value	S

- S Static error: The error display remains valid until the error has been cleared.
 D Dynamic error: For 5 s after its occurrence, the error is displayed instead of the room temperature. The display then reverts to normal. If the error persists, it can be displayed again by pressing the + or – button. Pressing the button again implements a setpoint adjustment.
 All other error codes indicate a hardware error.

Disposal



The device is classified as waste electronic equipment in terms of the European Directive 2002/96/EC (WEEE) and should not be disposed of as unsorted municipal waste.

The relevant national legal rules are to be adhered to.

Regarding disposal, use the systems setup for collecting electronic waste.

Observe all local and applicable laws.

Technical data

Supply voltage



Operating voltage range

SELV / PELV DC 12 ... 15 V

The device receives its power from the connected controller via the PPS2 interface

Power consumption (from controller)

Max. 0.10 VA

Operating data	Temperature sensor		
	Measuring element	NTC resistance sensor	
	Measuring range	0 ... 40 °C	
	Response time	≤ 10 min	
	Measuring accuracy (5 ... 30 °C)	± 1.0 K	
	Measuring accuracy (25 °C)	± 0.5 K	
	Setpoint correction		
	Correction range (defined by controller)	Max. ± 10 K (basic setting ± 3 K)	
	Accuracy over full correction range	10 %	
Display	Type	LCD	
	Functions displayed	<ul style="list-style-type: none"> – Room temperature – Setpoint adjustment – Operating mode (/ Auto) – Manually selected fan speed – Control sequence – Type of error – RXB/RXL parameter setting 	
Ports/interfaces	Type of port between controller and room unit	PPS2 (point-to-point interface, V 2)	
	Signal voltage, logic 0	< 5 V	
	Signal voltage, logic 1	> 7 V	
	Baud rate	4.8 kbps	
Cable connections	Connection terminals (screw terminals)	Solid or stranded conductors 0.8 ... 2.5 mm ²	
	Single cable length between controller and room unit	See installation guides: DESIGO RXC: CA110334, DESIGO RXB & RXL: CM110381 DESIGO RXA: CA2Z3884 DESIGO PX: CA110396	
	Cable type	2-core, twisted pair, unshielded	
Housing protection	Protection standard to EN 60529	IP 30	
Protection class	Insulation protection class	III	
Ambient conditions	IEC 721	Normal operation	Transport
	Environmental conditions	Class 3K5	Class 2K3
	Temperature	0 ... 50 °C	– 25 ... 70 °C
	Humidity	< 85 % rh	< 95 % rh
	Mechanical conditions	Class 3M2	Class 2M2
Standards and directives	Product standard Automatic electronic controls for household and similar use	EN 60730-1	
	Electromagnetic compatibility		
	Immunity (industrial & domestic)	EN 60730-1	
	Emissions (domestic)	EN 60730-1	
	 compliance		
	Meets requirements of EMC directive	2004/108/EC	
	 C-Tick conformity (EMC)	AS/NZS 61000-6-3	
Environmental compatibility	The product environmental declaration	ISO 14001 (Environment)	
	CE1E1640 contains data on RoHS compliance, materials composition, packaging, environmental benefit, disposal	ISO 9001 (Quality)	
		2002/95/EC (RoHS)	
Dimensions	See "Dimensions"		
Color	Front plate	NCS S 0502-G ≈ RAL 9003 signal white	
	Housing base, mounting plate and bias switches	RAL 7035 (light gray)	
Weight	Excluding packaging	0.119 kg	

Electrical connections

Terminal layout

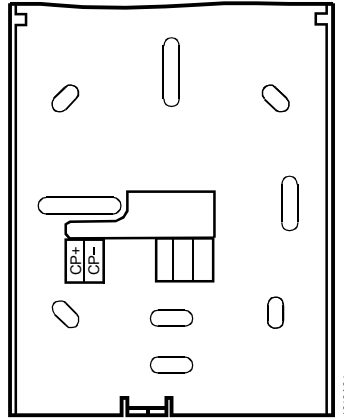

PPS2 interface, power supply

- CP+ 1 Device power supply, PPS2 data (positive)
- CP- 2 Device power supply, PPS2 data (negative)

Wiring diagram

The example below shows the room unit connected to a DESIGO RXB room controller.

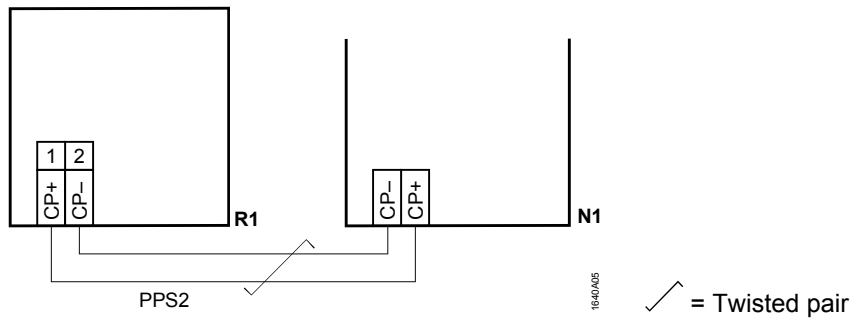

- R1 QAX34.3 room unit
- N1 RXB... room controller

Dimensions

Dimensions in mm

